



ICBO Evaluation Service, Inc.

5360 WORKMAN MILL ROAD • WHITTIER, CALIFORNIA 90601-2299

A subsidiary corporation of the International Conference of Building Officials

Accredited by the
American National Standards Institute

EVALUATION REPORT

Copyright © 2000 ICBO Evaluation Service, Inc.

ER-4528

Reissued December 1, 2000

Filing Category: DESIGN—Masonry (038)

EARTHSTONE S RETAINING WALL SYSTEM
HOKANSON BUILDING BLOCK CO./PAVESTONE
CALIFORNIA LLC
4751 POWER INN ROAD
SACRAMENTO, CALIFORNIA 95826

1.0 SUBJECT

Earthstone S Retaining Wall System.

2.0 DESCRIPTION

2.1 General:

The Earthstone S Retaining Wall System utilizes a concrete revetment-type block for construction of gravity retaining walls. The walls are constructed in running bond without mortar, grout or reinforcement. Earthstone S blocks are 14.8 inches (375.9 mm) deep, 5.5 inches (139.7 mm) high, 11.8 inches (299.7 mm) wide and weigh 73 pounds (33 kg). The blocks may be assembled in a closed (solid) configuration, open arrangement or alternating courses of closed and open. The blocks are spaced in the open arrangement to provide maximum 5.9-inch-wide (149.9 mm) gaps. Dimensional tolerances for Earthstone S units are plus or minus $\frac{1}{8}$ inch (3.2 mm) for the overall width, depth and height. They are Type I Grade N units complying with UBC Standard 21-4 except for a minimum 28-day compressive strength of 4,000 psi (27.6 MPa) using Type I or Type II portland cement.

2.2 Design:

The Earthstone S Retaining Wall System utilizes its weight and geometry to resist lateral soil pressures and other lateral forces. A soils investigation report, as noted in Section 1804.3 of the code is required. It must include soil properties (unit density, soil friction angle for a range of normal pressures anticipated) for backfill soil, retained excavation soil and foundation soil as applicable. Lateral loads shall be determined by accepted geotechnical engineering procedures appropriate for the soil and geometric conditions specified for the wall, and must address the applicability of the Earthstone S system in seismically active areas. The effect of surcharges must be considered. The lateral soil pressure is determined by the Coulomb theory with the angle of wall friction assumed to be two thirds the angle of internal friction.

2.3 Assembly:

The minimum angle of wall inclination is 10 degrees from vertical towards the backfill. For walls having an angle of inclination greater than 15 degrees from the vertical, the lateral soil pressure determined by the Coulomb theory is multiplied by a factor of 1.2. A blanket of compacted, cohesionless backfill consisting of $\frac{3}{4}$ -inch (19.1 mm) gravel or Class II permeable material is placed behind the wall. The minimum width of the backfill blanket is determined by the soils engineer. The groundwater table must be a minimum distance of 3 feet (914

mm) below the bottom of the footing. Soils with poor drainage qualities must have a perforated drain line system to prevent hydrostatic pressure buildup behind the wall. The in-place wall is limited to a maximum cumulative tolerance of $\pm \frac{1}{4}$ inch (6.4 mm) from specifications, measured every 10 feet (3048 mm) along both wall height and width. Each block course must be placed to a tolerance of $\pm \frac{1}{4}$ inch (6.4 mm).

The top course of the retaining wall system must be a closed assembly set in mortar or epoxy adhesive. The bottom course is also a closed assembly set in wet footing concrete or epoxy grout using a template to assure the correct angle of inclination (tilt) of the wall.

Earthstone S blocks may be assembled in a curved layout with a minimum radius of 9 feet (2743 mm) measured from the back face (earth face) of the bottom course and the outside face (exposed face) of the top course. The maximum wall height for curved walls is the same as permitted for an open assembly. Outside face gap is limited to 5.9 inches (149.9 mm) for curved open arrangements.

2.4 Structural Design:

Structural calculations must be submitted to the building official for each wall system. The structural analysis is based on accepted engineering principles and Section 2107 of the code, except where otherwise specified in this report. As required by Sections 1802 and 1805 of the code, the allowable stress design load combinations specified in Section 1612.3 of the code must be considered. All contact surfaces of the units must be maintained in compression, i.e., no tension stresses. Maximum allowable compression stress is 100 psi (689 kPa). Coefficient of friction between blocks is 0.6. A drawing of each block size is to be included with the design description indicating the portion of contact surfaces that resist sliding between blocks. Wall must be designed to provide a minimum safety factor against sliding between units of 1.5. Foundations must be designed to provide a minimum safety factor against overturning and sliding of 1.5. See Figures 1, 2, and 3 for additional details.

2.5 Inspection:

Special inspection is required for backfill placement and the angle of wall inclination. Inspection with a template, available from the manufacturer or as designed by the engineer, is required to assure proper angle of wall inclination.

2.6 Identification:

Each shipping pallet is identified with the company name (Pavestone), the name Earthstone S and the ICBO ES evaluation report number (ICBO ES ER-4528).

3.0 EVIDENCE SUBMITTED

Descriptive literature and calculations.

Evaluation reports of ICBO Evaluation Service, Inc., are issued solely to provide information to Class A members of ICBO, utilizing the code upon which the report is based. Evaluation reports are not to be construed as representing aesthetics or any other attributes not specifically addressed nor as an endorsement or recommendation for use of the subject report.

This report is based upon independent tests or other technical data submitted by the applicant. The ICBO Evaluation Service, Inc., technical staff has reviewed the test results and/or other data, but does not possess test facilities to make an independent verification. There is no warranty by ICBO Evaluation Service, Inc., express or implied, as to any "Finding" or other matter in the report or as to any product covered by the report. This disclaimer includes, but is not limited to, merchantability.

4.0 FINDINGS

That the Earthstone S Retaining Wall System complies with the 1997 *Uniform Building Code*™, subject to the following conditions:

- 4.1 Earthstone S units are verified as complying with Section 2.1 of this report.
- 4.2 The system is installed in accordance with this report and the manufacturer's instructions.

4.3 Retaining walls are individually designed in accordance with recognized engineering principles and design parameters in this report. The design must be approved by the building official.

4.4 Special inspection is required for the backfill placement and angle of wall inclination.

4.5 Soil report is required as noted in Section 2.2.

This report is subject to re-examination in two years.

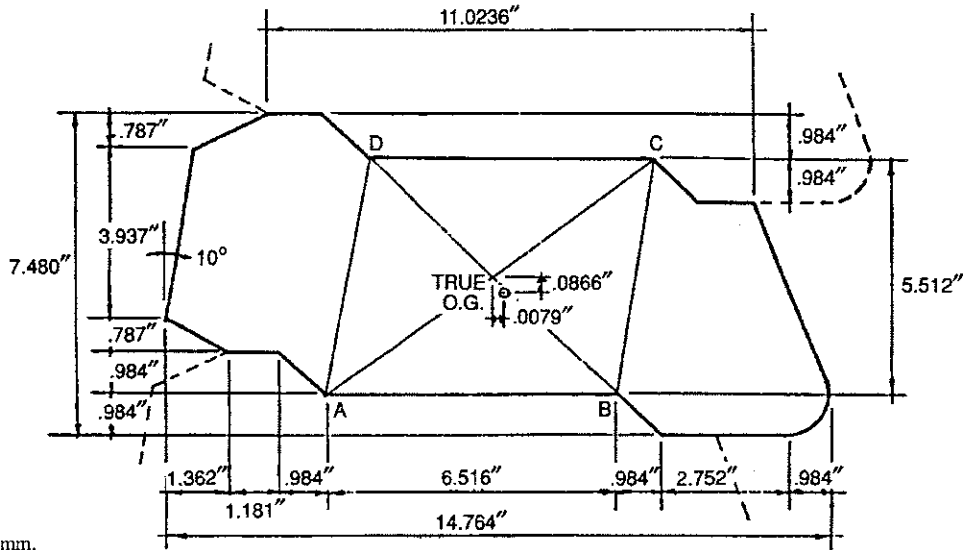

For SI: 1 inch = 25.4 mm.

FIGURE 1—EARTHSTONE S BLOCK

BLOCK LENGTH	= 11.81 inches (300 mm).
CROSS SECTIONAL AREA	= 77.08 square inches (49 729 mm ²).
APPROXIMATE EXPOSED SURFACE AREA PER BLOCK UNIT	= 0.452 square inches (291.6 mm ²).
WEIGHT PER BLOCK	= 73 pounds (33 kg).
UNIT WEIGHT OF WALL STEM IN CLOSED ASSEMBLY (per square feet of wall surface)	= 161.5 pounds per square foot (7732.7 Pa).
APPROXIMATE NUMBER OF BLOCK UNITS PER SQUARE FOOT OF WALL SURFACE	= 2.212.

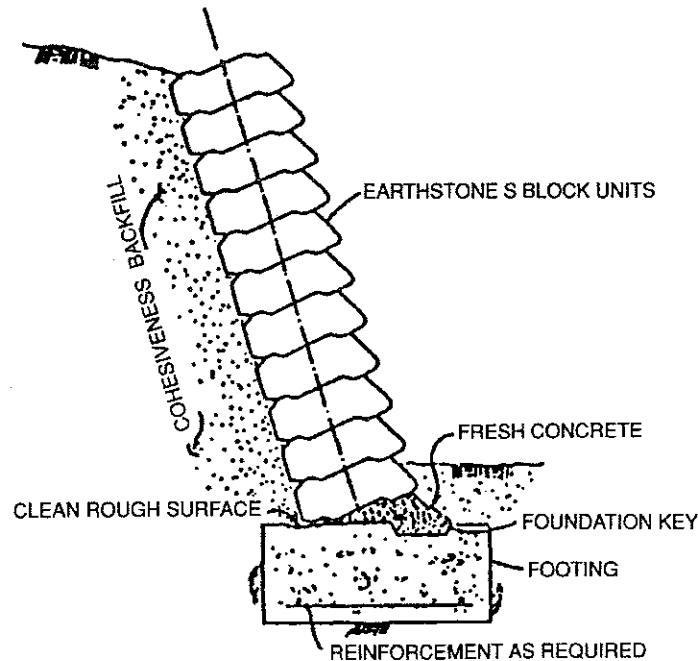
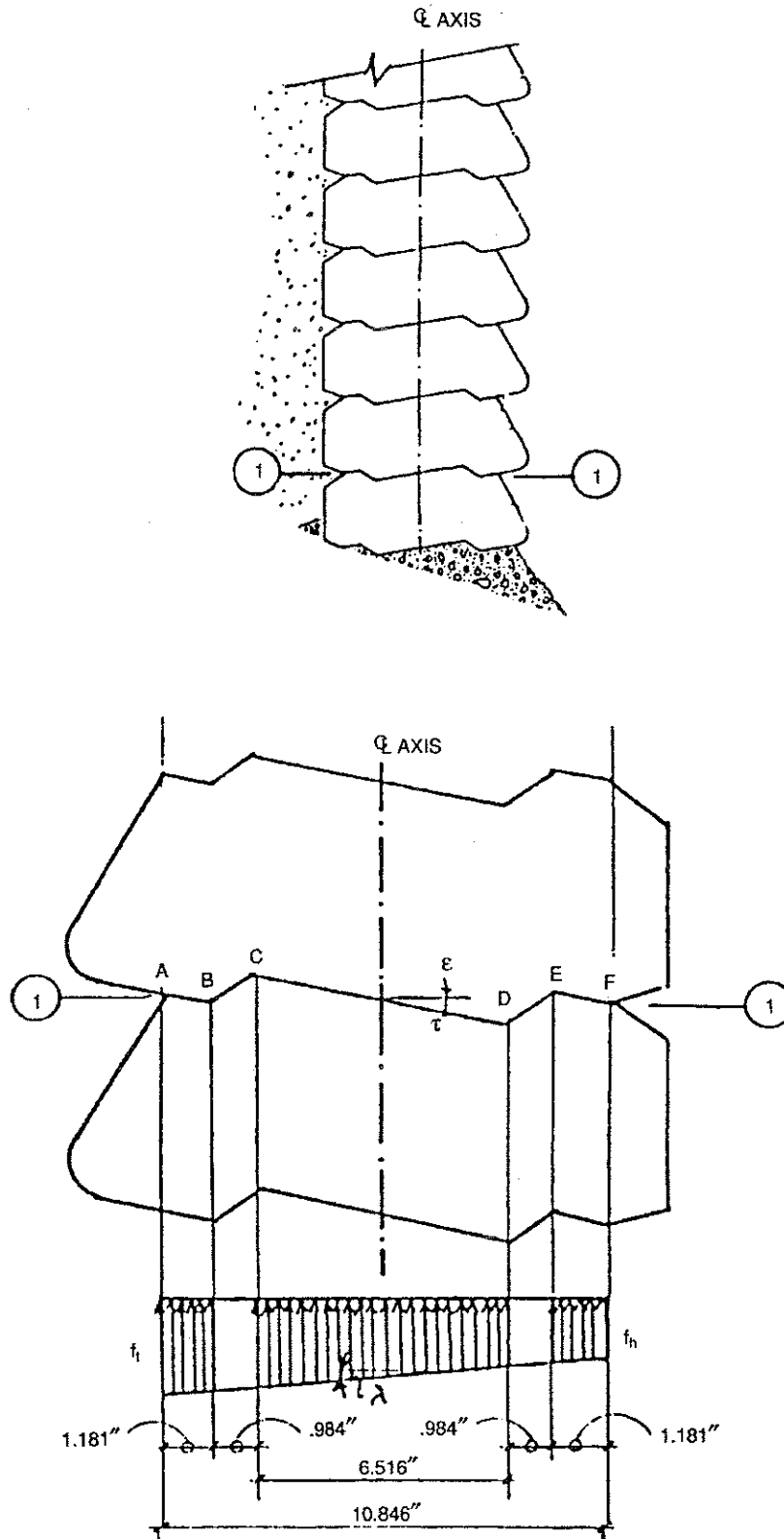

FIGURE 2—TYPICAL INSTALLATION



For SI: 1 inch = 25.4 mm.

FIGURE 3—CONTACT SURFACE AT "DRY" JOINT